



# PROJECT DESIGN GUIDE D03 'DESIGN INFORMATION FLOW MAPPING'

Project Name: <i>Name</i>	Project No.: <i>Number</i>	Date: <i>Date</i>
------------------------------	-------------------------------	----------------------

Document No.: **PDG-PDG-PRO-D03.0** Date Created: **8<sup>th</sup> June 2012** Date Revised: R01 06.06.2014

<b>Revision:</b>	<b>Revision description:</b>	<b>Revision date:</b>
01	Guide list omitted, graphics updated, alpha codes updated.	6 June 2014
02		
03		

<b>Edited to be project specific / Revised by:</b>	
Name:	Position:
Signature:	Date:
<b>Checked by:</b>	
Name:	Position:
Signature:	Date:
<b>Authorised by:</b>	
Name:	Position:
Signature:	Date:

---

**Document Distribution:**

Name	Company	Status	Date
		<b>A</b>	00/00/2012

Status key:

**A** – Action**I** – Information

---

## 1.0 Introduction

There are several important flows of design information that, for clarity, benefit from being illustrated. It is important to check the main contract documents for explicit time scales and inclusion of client processes. Creating flow charts of the project design process highlights the complexity of service required to manage the project design, an important factor, in addition to complexity of the design itself, when bidding for a project and when managing fees / resources.

The following are examples only, and may need to be redrawn to be project specific. They form a hierarchy, from overall project process to drilling down into the detail of individual actions.

Flow charts included:

Flow Chart 1: Project Process Map for Design.

Flow Chart 2: Design Team Drawing Life Cycle.

Flow Chart 3: Design Team Information Approval Process Iteration Diagram.

Flow Chart 4: Approval process (Consultants and sub-contractors).

Flow Chart 1: Project Process Map for Design: illustrates the complexity of service, inter-relationships, and highlights busy stages.

Flow Chart 2: Design Team Drawing Life Cycle: maps out the journey for any particular piece of design information. Importantly informs on approval process/es, which stage/s they need to happen and if there is a client approval process.

Flow Chart 3: Design Information Approval Process Iteration Diagram: gives clear guidance on the likely length of parallel and sequential approval processes, with a realistic second iteration incorporated. The Project Planner should include this as float when programming.

Flow Chart 4: Approval process (Consultants and sub-contractors): drills down to individuals, indicating responsibilities, tasks and timescales, as well as the flow between parties.

Note: these flow charts do not relate to BIM.

These flow charts create a quick easy tool for briefing other team members and are particularly important for informing Project Planning, on the inter-relationships, time scales and float required in the detail of the processes.

## 1.0 Decisions

With every process map there are decisions to be made. The following are possible items to consider. Amend as required:

- If there is a Client process how does this effect / dictate the information flow.
- Understand the processes (i.e. BREEAM points are gained from the early stages).
- What stages do drawings need approval for:
  - Every stage issue,
  - Tender & Construction,
  - Construction only.
- What approval time scales are allowed for, for each party.
- Is the Contractors Design Manager the lead reviewer?

Stage	To be Approved by the Contractor	To be Approved by the Client
Prelim	NO	NO
LA Planning	YES	YES
Tender	YES	NO
Construction	YES	YES
Record information	YES	YES

Table 1.0 Stages to be approved (amend as required)

## 2.0 Managing this Document

Once set up this document should not need amending. Care should be taken to ensure this document is right first time. To change flow charts part way through the design process will cause great confusion.

**Flow Chart 1: Project Process Map for Design**  
 Amend to be project specific

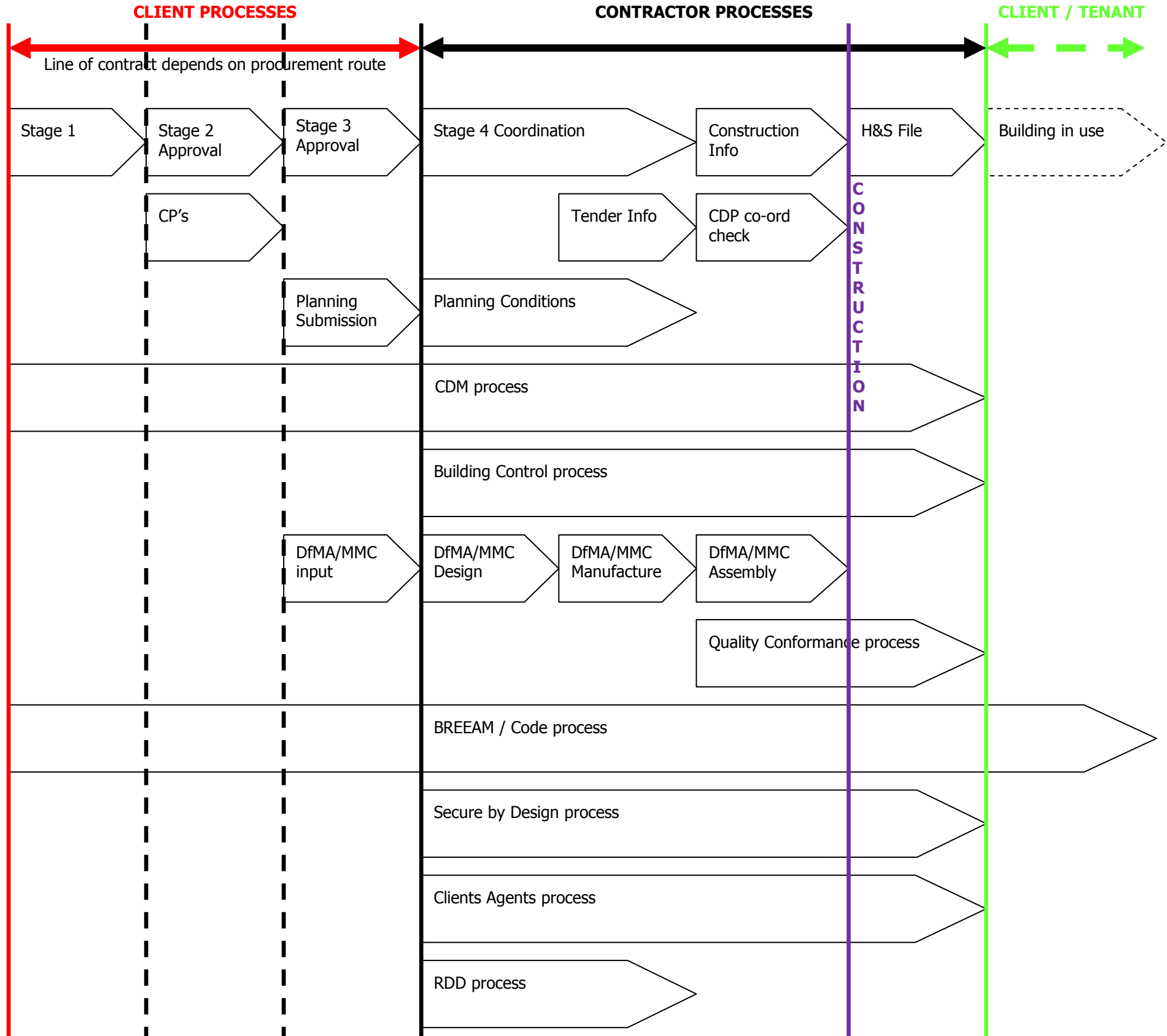

**Flow Chart 2: Design Team Drawing Life Cycle RIBA stage 3 onwards**  
 Amend as appropriate

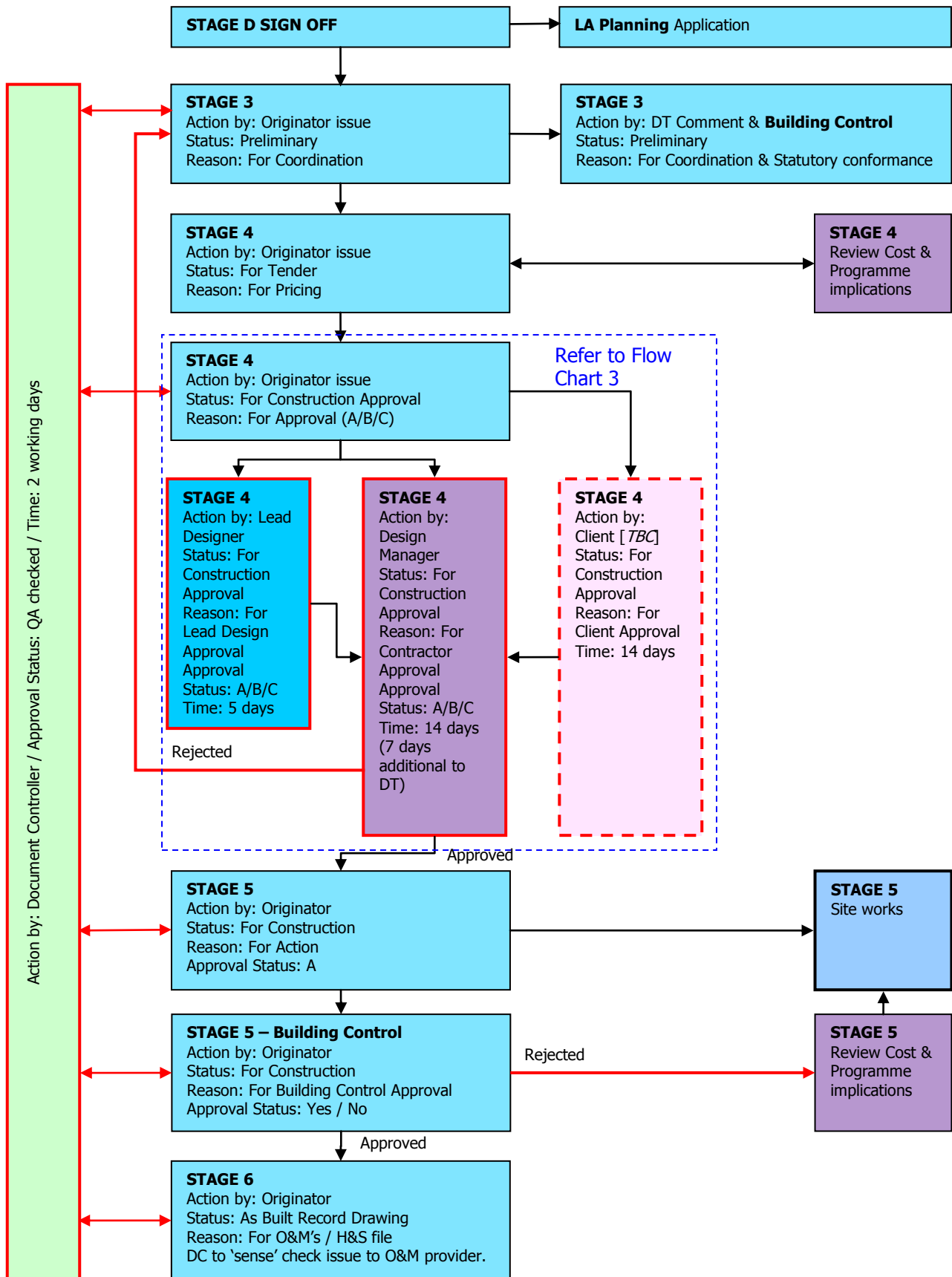

**Flow Chart 3: Design Information Approval Process Iteration Diagram**

Contractor and Client **parallel** process

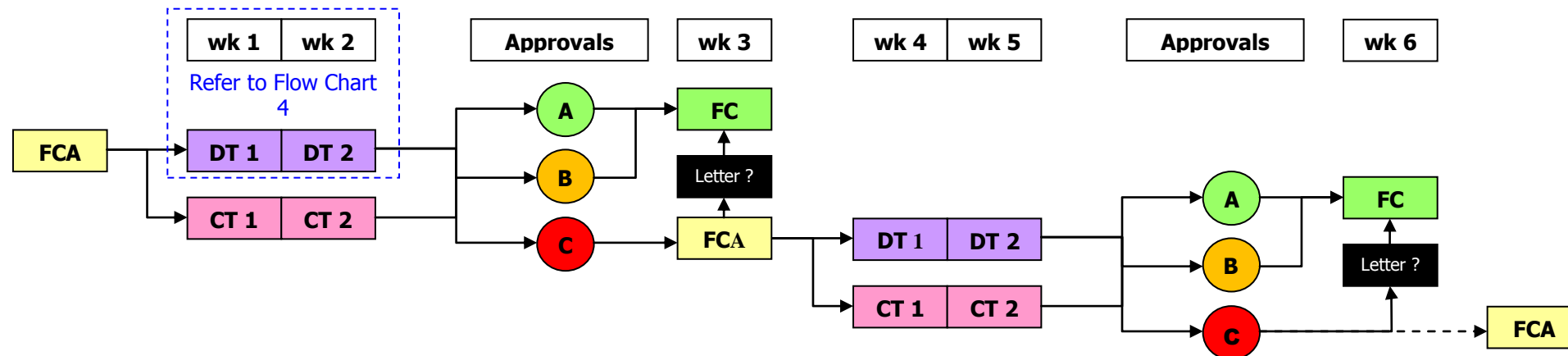

Contractor and Client **Sequential** process

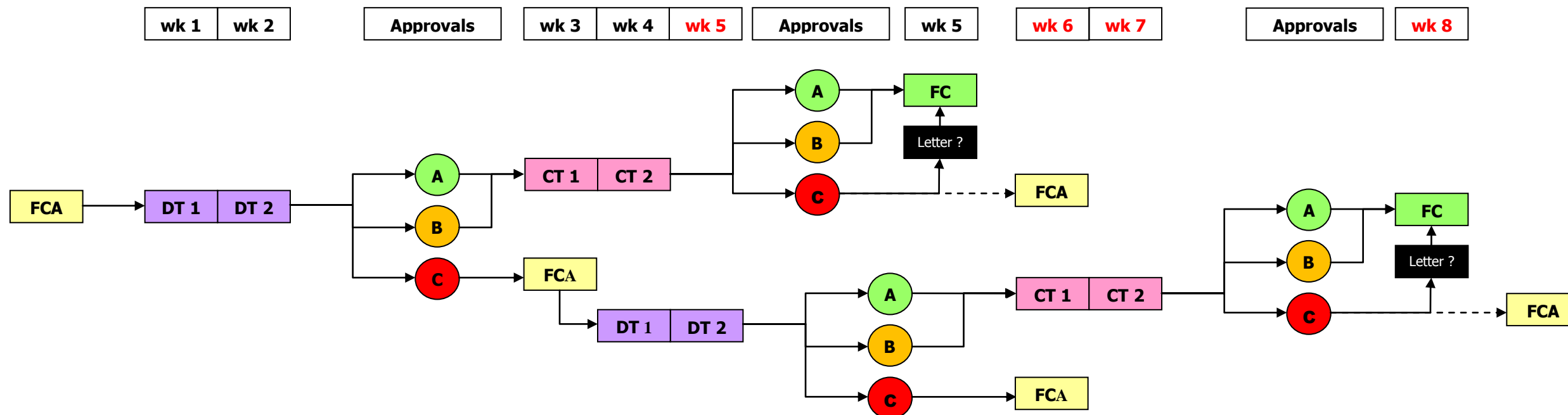

- Key:**
- FCA For Construction Approval
  - DT 1 Design Team approval week/s
  - CT 1 Client Team approval week/s
  - FC For Construction

Note: Time scales for the Parallel process above are the same with or without client involvement.



**Flow Chart 4: Approval process (Consultants and sub-contractors)**  
 (without client approval process) – [amend as appropriate](#)

